

# ESM-52x, ESM-54x, ESM-57x

Safety mat signal generators

<b>1</b>	<b>Description</b>	<b>2</b>	<b>4.3</b>	<b>Mounting</b>	<b>4</b>
1.1	Function	2	4.4	Connection to switching device	4
1.2	Product version	2	<b>5</b>	<b>Operation</b>	<b>5</b>
<b>2</b>	<b>Δ Safety instructions</b>	<b>2</b>	5.1	Maintenance	5
<b>3</b>	<b>Storage and transportation</b>	<b>2</b>	5.2	Faults	5
<b>4</b>	<b>Installation</b>	<b>3</b>	<b>6</b>	<b>Technical data</b>	<b>5</b>
4.1	Mounting position requirements	3	<b>7</b>	<b>Contact</b>	<b>6</b>
4.2	Functional testing	3			

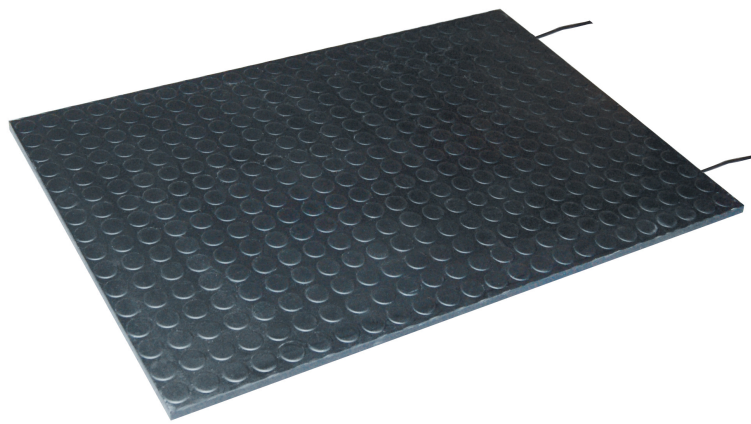

Type properties:

- 52** Rectangular with standard dimensions
- 54** Rectangular with variable dimensions
- 57** Freeform with variable dimensions
- x** Placeholder for variant

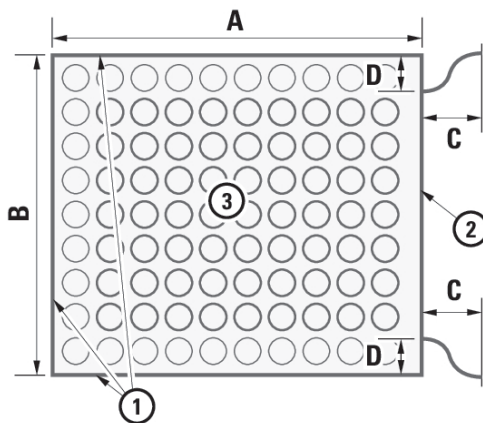

Elements:

- 1** Active switching edge (optional)
- 2** Non-switching edge with connection cables
- 3** Pressure-sensitive surface

Configuration dimensions:

- A × B** Sensor dimensions
- C** Connection cable length
- D** Distance between cable and corner

# 1 Description

## 1.1 Function

The product is suitable as a sensor for use in safety mats.

Safety mats are pressure-sensitive protection devices that consist of a sensor and a safety switching device. The safety switching device assumes the function of signal processor and output switching device.



### NOTE

#### EN ISO 13849-1, protection devices

The sensor is suitable for use in safety mats that have to meet the requirements of performance level PL e cat. 3.





### NOTE

#### EN ISO 13856-1, pressure-sensitive protection devices

Standard-compliant use of the sensor in safety mats requires the use of a safety switching device that has been specified by the manufacturer of the sensor and subjected to the mandatory conformity assessment procedure.

Outside of protection devices, the product can be used as a sensor, even without a safety switching device.

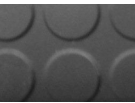
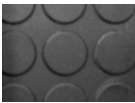
## 1.2 Product version

x	A	D or M	G
Variant	ESM 54A ESM 57A	ESM 52D/M ESM 54D/M ESM 57D/M	ESM 54G ESM 57G
Pressure-sensitive surface			
Structure	Grip pads	Grip pads	Smooth
Diameter	25.0	23.0	-
Distance	29.5	25.0	-
Grip pad height	1.0	1.4	-

Dimension in mm

### Active switching edge

Sensor versions D and M can be combined into safety mat systems.

The adjacent edge joints must be active switching edges.



The active switching edges have a smaller grip pad height: 0.4 instead of 1.4 mm.

### Connection cable

Standard equipment:

- 2 cables, each with 2 conductors

Customer-specific equipment may deviate, e.g.:

- 1 cable with 4 conductors
- 1 cable with 2 conductors, integrated termination resistor 8.2 kΩ

In case of customer-specific equipment, observe any additionally provided drawings and connection documents.

## 2 Safety instructions

Read the operating instructions carefully before commissioning the device. Keep the instructions for future use.

### Intended use

The manufacturer is only liable for products used as intended. Only use this product for the function specified:

Safety mat signal generators

### Personnel qualification

Only trained and qualified personnel may install and commission the device.

The installer is responsible for installing the device and the connected system in accordance with the regulations and standards.

### General safety instructions

It is the responsibility of the equipment installer to carry out a risk assessment and to install the system, in compliance with applicable regulations and safety standards.

The cables must be protected against mechanical damage.

## 3 Storage and transportation

Store and transport pressure-sensitive mat sensors as follows.

Note:

- Always transport in the provided packaging
- Store dry, clean, flat
- Stack max. 10 units or as packaged

Avoid:

- Bending
- Stacking sensors of different sizes
- Storage in extreme temperature fluctuations
- Storage outdoors
- Pulling on the cable

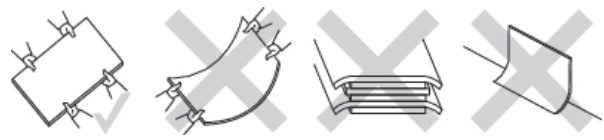

## 4 Installation

### 4.1 Mounting position requirements

#### Flat mounting surface

The surface intended for mounting must be flat.

- ▶ Remove any particles and localized raised areas.
- ▶ Even out edges or holes in the surface.



#### NOTE

##### Floor condition:

A floor with a surface condition in accordance with construction standard DIN 18202, table 3, row 4, meets all requirements for the pressure-sensitive mat sensor mounting surface.

#### Dry surfaces

The polyurethane (PUR) coating of the sensor can absorb moisture. Lasting and standing moisture in particular can damage the sensor and/or cause false triggering. In damp environments and outdoors, take precautions to drain moisture, e.g. by mounting on a grating:

#### Mounting example with grating (section)

- ▶ Place the sensor on a back-ventilated grating.
- ▶ Make sure that water on and under the sensor can drain.
- ▶ Do not place any water-retentive materials (e.g. fleece) under the sensor.

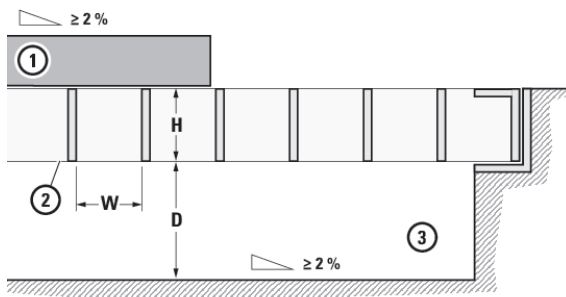

- 1 Pressure-sensitive mat sensor
  - 2 Grating, top smooth, without toothings, without slip resistance, with incline
  - 3 Back ventilation, with incline and water drain
- W Grating mesh size: min. 10 mm, max. 33 mm (lengthwise and crosswise)
- H Grating height: to be determined on site
- R Back ventilation height: to be determined on site, min. 40 mm recommended

- ▶ Fasten the edges of the sensor.
- ▶ In mounting zone F, only load the edge with clamping devices.
- ▶ For thermal expansion, allow the sensor a gap of 1 mm around the clamping device.

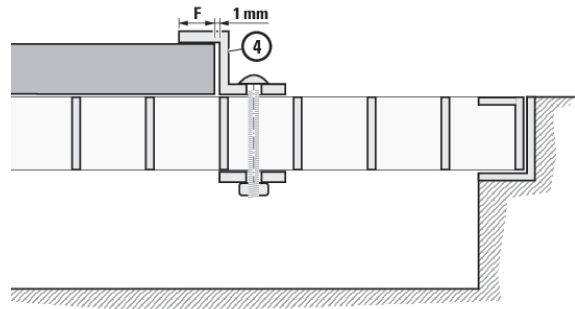

4 Clamp or clamping profile

F Mounting zone max. 5 mm

- ▶ If necessary, integrate the cabling into the clamping profile.
- ▶ Make sure that the cross-section R of the back ventilation is not reduced by the mounting device.

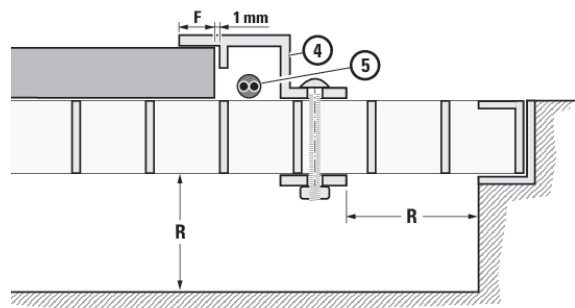

4 Clamping profile or Z-rail

5 Connection cable

F Mounting zone

R Back ventilation cross-section

#### Protected cable routes

In case of temperature fluctuations in the environment, connection cables are also used for pressure equalization in the sensor. A lack of pressure equalization can result in unintended triggering or damage to the sensor.

Connection cable routing:

- ▶ Bending radius min. 50 mm
- ▶ Cable ends must always be dry and clean (during transportation, mounting and operation).
- ▶ Cables must not be crushed.
- ▶ Do not pull on the cables.

#### 4.2 Functional testing

Before laying safety mat systems especially, it can make sense to rule out any transport damage.

Individual testing of sensor (standard version):

- 1) Connect the two conductors of a cable to a termination resistor 8.2 kΩ.
- 2) Measure the electrical resistance between the two conductors of the other cable.

If the sensor is working, the measurement results in:

- 8.2 k $\Omega$ , as long as the sensor is not under a load.
- The value falls to 0  $\Omega$  as soon as the sensor is stepped on.

### 4.3 Mounting

- 1) Calibrate the position of the sensor.
- 2) If you want to combine multiple sensors into a safety mat system, note the arrangement:
  - Only make contact with the sensors at active switching edges (marked in gray)
  - Offset corner points by at least 50 mm

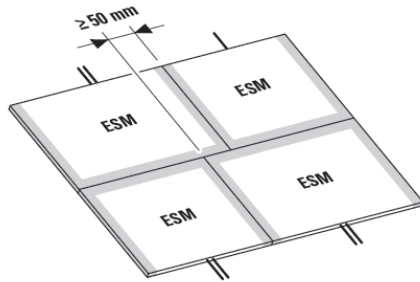

- 3) Install the sensor with the type plate facing down. The grip pads should always be on the top side.



#### NOTE

#### Recommendation for safety mat systems:

- Use the connection strips (optional) to install the sensors.

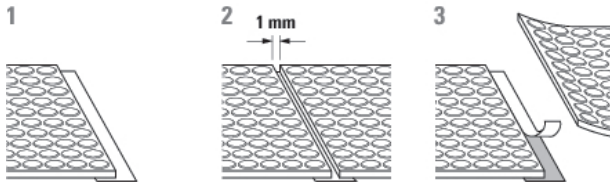

#### Installation with connection strips

- 1 Remove the protective film **from only one-half** of the connection strip. Apply this half under the edge of the sensor.
- 2 The other half of the connection strip is not applied yet. Place the neighboring sensor on it. Create a 1 mm gap between the sensors (e.g. using an aluminum strip).
- 3 Step onto the newly created sensor. Lift the edge joint slightly. Remove the protective film from the other half of the connection strip. Press the edge joint onto the adhesive surface.
- 4) Lay the cables. The cables are air-permeable and are used for pressure equalization.



#### CAUTION

#### Sensors can be damaged due to insufficient pressure equalization.

Ensure pressure equalization by the cables:

- Do not bend or clamp the cables.
- Always keep the cable ends dry.
- Only hand-tighten the cable glands.
- Use air-permeable connection housings.

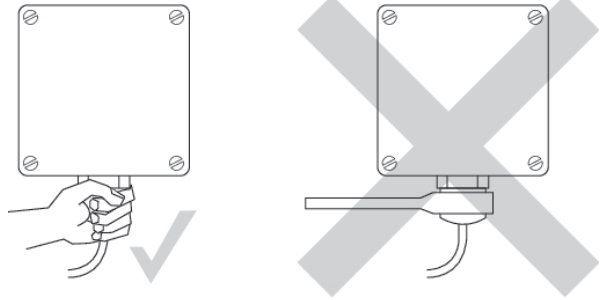

- 5) Fix the edges of the sensor with mounting rails. For edges in paths, use ramp rails (shown with corner connectors).



#### Mounting dimensions:

- Distance between outer edge of rail to outer edge of sensor according to drawing

#### Tolerance to thermal expansion:

- Distance from mounting stop to sensor for thermal expansion approx. 1 mm

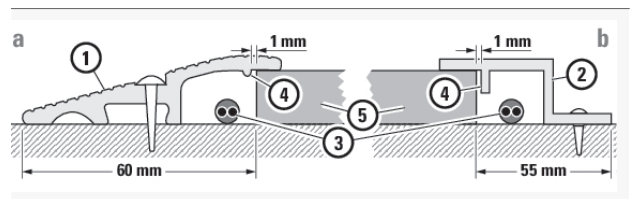

#### Mounting rails (section)

- 1 Ramp rail for mounting in path
- 2 Z-rail for mounting in front of an object
- 3 Cabling, preferably under Z-rail
- 4 Mounting stop with distance to sensor
- 5 Sensor

### 4.4 Connection to switching device

- 1) Read and follow the operating instructions for the switching device. Observe any system-specific planning documents from the manufacturer.



## NOTE

### Performance level PLe:

The requirements for PLe for safety mats are met with ESM series sensors in combination with Bircher type ESD3 or EsMatix3 safety switching devices.



## NOTE

### Cable variants

- The sensor is equipped with two 2-conductor cables as standard. Connect the sensor as described in the following.
- Optionally, the sensor is only equipped with one 2-conductor cable and an integrated termination resistor. Connect this sensor directly to the switching device separately.
- Sensors optionally equipped with one 4-conductor cable are connected like those with two 2-conductor cables. You can get additional connection diagrams by arrangement.

- 2) Connect 1 sensor or a series of up to 4 sensors to the switching device as shown in the figure.
- 3) Connect the remaining free cable ends to a termination resistor 8.2 kΩ.

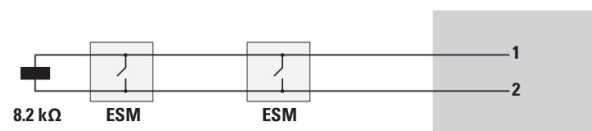
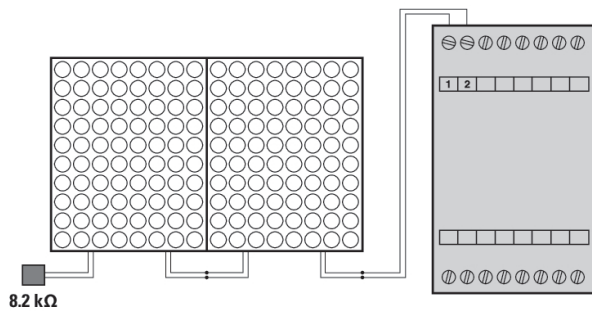

Termination-resistor    Sensor    Safetyswitching device

## 5 Operation

### 5.1 Maintenance

#### Monthly

- ▶ Test the function of each sensor by applying manual pressure.

### 5.2 Faults

#### Fault pattern

Possible causes    ▶    Possible remedies

### Sensor permanently "conductive" without pressure

Contact damaged due to deformation    ▶    Replace the sensor.

### Sensor permanently without switching function

Cable break    ▶    Check the cable connection.

### Sensor without measurable resistance of 8.2 kΩ

Termination resistor missing or defective    ▶    Replace or add the termination resistor.

Cable break    ▶    Check the cable connection.

## 6 Technical data

### Mechanical data

Surface material	Polyurethane (PUR)
Material composition (> 1 % by weight)	Polyurethane, fiberglass epoxy resin, copper
Material hardness	80 ±5 Shore A
Force to activate the sensor	Typically 100 N, max. 350 N with test piece Ø 80 mm
Resilience	1 million loads × 1000 N with test piece Ø 80 mm acc. to EN ISO 13856-1
Fork lift truck vehicle capacity, tested	6000 × 2000 kg with hard rubber roller, 90 mm wide

### Technical data

Performance level	Sensor suitable for safety mats with PLe, cat. 3 according to EN ISO 13849-1 (type testing according to EN ISO 13856-1)
-------------------	-------------------------------------------------------------------------------------------------------------------------

### Electrical data

Protection class (without cable ends)	IP 67 (acc. to EN 60529)
Insulating strength	> 1500 V AC
Cable type, standard	2 × 0.5 mm <sup>2</sup>
Cable length, standard	300 mm, with plug connector
Cable length, maximum	5000 mm, without plug connector

### Ambient conditions

Ambient temperature (operation and storage)	min. -25°C, max. +75°C
Chemical resistance	Weather, ozone, oils, gasoline, water 20°C, solvent, acids

### Disposal information



The product contains electrical or electronic components. Do not dispose of the product with household waste.

## Notice on conformity

---



BBC Bircher AG declares that this product conforms with the following guidelines and directives of the EU:

MD 2006/42/EC  
RoHS 2011/65/EU WEEE 2011/19/EU

EC type-examination certificate:  
E 7012; E 7013; E 7014 1246

Follow the QR code or link below for the detailed declaration of conformity.

---

---

**SWISSDOOR**  
DØRTEKNIK FOR PROFESSIONELLE

### SWISSDOOR APS

Industrivej 4A  
DK-5471 Sønderød  
www.swissdoor.dk  
mail@swissdoor.dk  
Tlf.: +45 8628 0000